

- Natural extract ventilator for heavy industry
- Highest efficiency
- For installation onto most kinds of roofs, either at the peak, down slope or flat.
- Continuous weatherproof ventilation for continuous extraction
- No operating costs
- Durable aluminium or steel

Options

- Shutter to reduce heat losses or to regulate airflow
- Sound baffles to reduce noise

MoffittVent is a ventilator especially suited to natural ventilation of industries where high volumes of heat are produced.

MoffittVent provides continuous extract ventilation for most kinds of industrial buildings, providing high volume ventilation. It is aerodynamically designed to provide continuous weatherproof ventilation. The unit can be adapted to accept sound absorbers.

Where a low profile, relatively low weight unit is required, we recommend the Colt Labyrinth as an alternative.



FEATURES AND BENEFITS

Efficient - MoffittVent is efficient in operation and provides continuous ventilation in all weather. It has 100% free area to face area ratio.

The ventilator is not affected by the direction or velocity of the wind - in fact its performance will increase in higher wind conditions.

Weather resistant – The ventilator’s design will not allow water entry into the building at any wind velocity. All water is collected by integral drain gutters and downspouts and re-directed out to the roof.

The ventilator has been designed to withstand wind speeds as high as 210 km/h (130 MPH) and can be easily designed for higher wind speeds if required.

Optional damper – An optional manual or motorized damper ensures that air leakage is kept to a minimum when ventilation is not required.

Various fixing options - MoffittVent can be installed onto most kinds of roofs, either at the peak, down slope or on a flat roof.

Easy to install - MoffittVent is delivered to site in breakdown form for easy local assembly.

Durable - MoffittVent is manufactured from tough, corrosion-resistant materials.

Low in maintenance – MoffittVent requires virtually no maintenance.

Design service - Colt provides a pre-order design service. Please contact Colt for more information relating to the application, specification, installation or servicing of MoffittVent.

SINGLE DAMPER MOFFITVENT VENTILATORS

Single damper MoffittVent (metric)				
Vent Size (mm)	A	B	C	Weight (kg)
610	610	876	1557	22.9
762	762	1059	1892	27.2
914	914	1236	2229	29.5
1067	1067	1430	2575	36.2
1219	1219	1582	2908	43.1

Single damper MoffittVent (imperial)				
Vent Size (inches)	A	B	C	Weight (pounds)
24	24"	34 1/2"	61 1/4"	55
30	30"	41 11/16"	74 1/2"	60
36	36"	48 7/8"	87 3/4"	65
42	42"	56 5/16"	101 3/8"	80
48	48"	62 3/8"	114 1/2"	95

DOUBLE DAMPER MOFFITVENT VENTILATORS

Double damper MoffittVent (metric)				
Vent Size (mm)	A	B	C	Weight (kg)
1371	1371	1773	3276	52.1
1524	1524	1966	3632	61.2
1829	1829	2349	4267	72.5
2134	2134	2702	5017	86.6
2438	2438	3048	5740	107.4
2743	2743	3607	6299	132.9
3048	3048	3785	6960	141.5
3353	3353	4064	7722	147.0
3658	3658	4521	8306	161.9
3962	3962	4801	9144	184.6
4267	4267	5080	9703	212.3
4572	4572	5461	10287	259.5

Double damper MoffittVent (imperial)				
Vent Size (inches)	A	B	C	Weight (pounds)
54	54"	69 7/8"	129"	115
60	60"	77 3/8"	143"	135
72	72"	92 1/2"	168"	160
84	84"	106 3/8"	197 1/2"	191
96	96"	120"	18' 10"	236
108	108"	11' 10"	20' 8"	293
120	120"	12' 5"	22' 10"	312
132	132"	13' 4"	25' 4"	324
144	144"	14' 10"	27' 3"	357
156	156"	15' 9"	30"	407
168	168"	16' 8"	31' 10"	468
180	180"	17' 11"	33' 9"	57

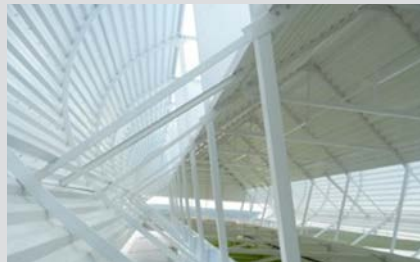

DIMENSIONAL INFORMATION

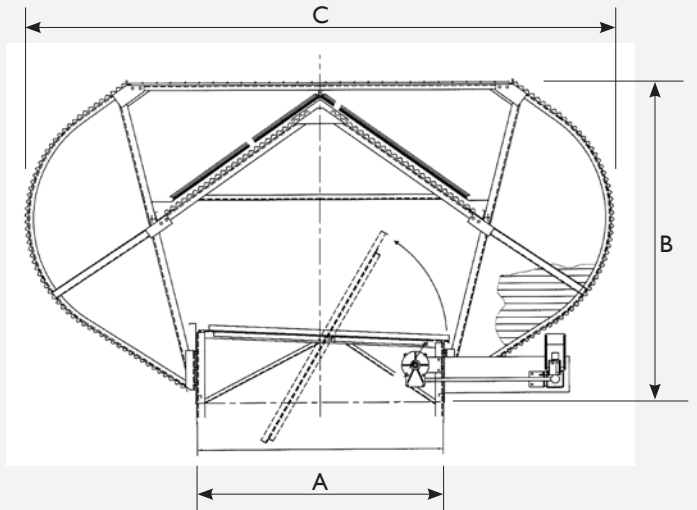

MV 24" (610mm) through to 48" (1220mm)

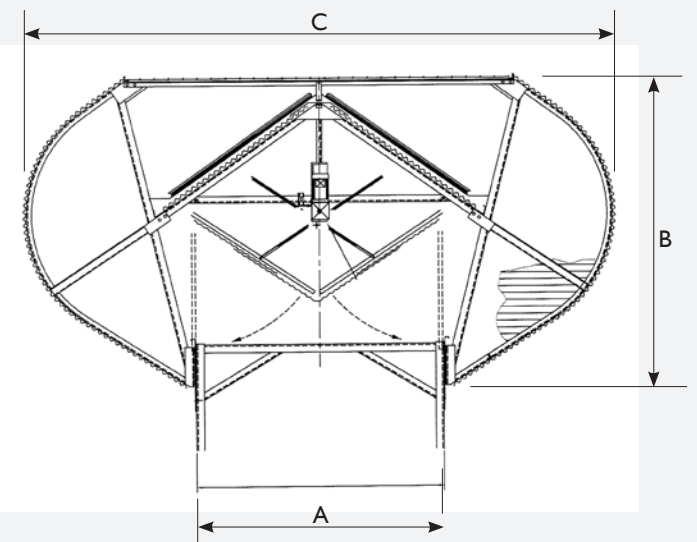

MV 54" (1371mm) through to 180" (4572mm)